

SW35S
SW35SW
SW35SB
SW35B

Installation Instructions

SYSTEMA

Systema | 358mm Wall Channel

Component Checklist

Wall Channel (x1)



Top Cap (x1)

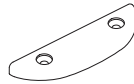

Top Cap Screws (x2)



M6 x 50mm
Countersunk
Screw (x3)



Nylon Anchor (x3)



Tools Required:

- Power Drill
- 5.5mm (1/4") Drill Bit
- 8mm (5/16") Drill Bit
- Phillips Head Screwdriver

IMPORTANT INFORMATION:

! IMPORTANT - Install Systema Wall Channel as per installation instructions.

! Refer to Systema Monitor arm or Monitor Spring Arm Installation Instructions for maximum load advice.

! The manufacturer accepts no responsibility for incorrect installations.

! The Systema Wall Channel is compatible with Systema Monitor Arms: SA13, SA46, SA71 and with Systema Monitor Spring Arm: SS.

Step 1. Check Components

Check what you have received against the component checklist and hardware above.

Step 2. Position Wall plate - Ergonomic Guidelines

Many experts believe that the extended use of any computer screen has the potential to cause serious injury to your eyes, neck and back. This can be largely avoided by correctly positioning your display.

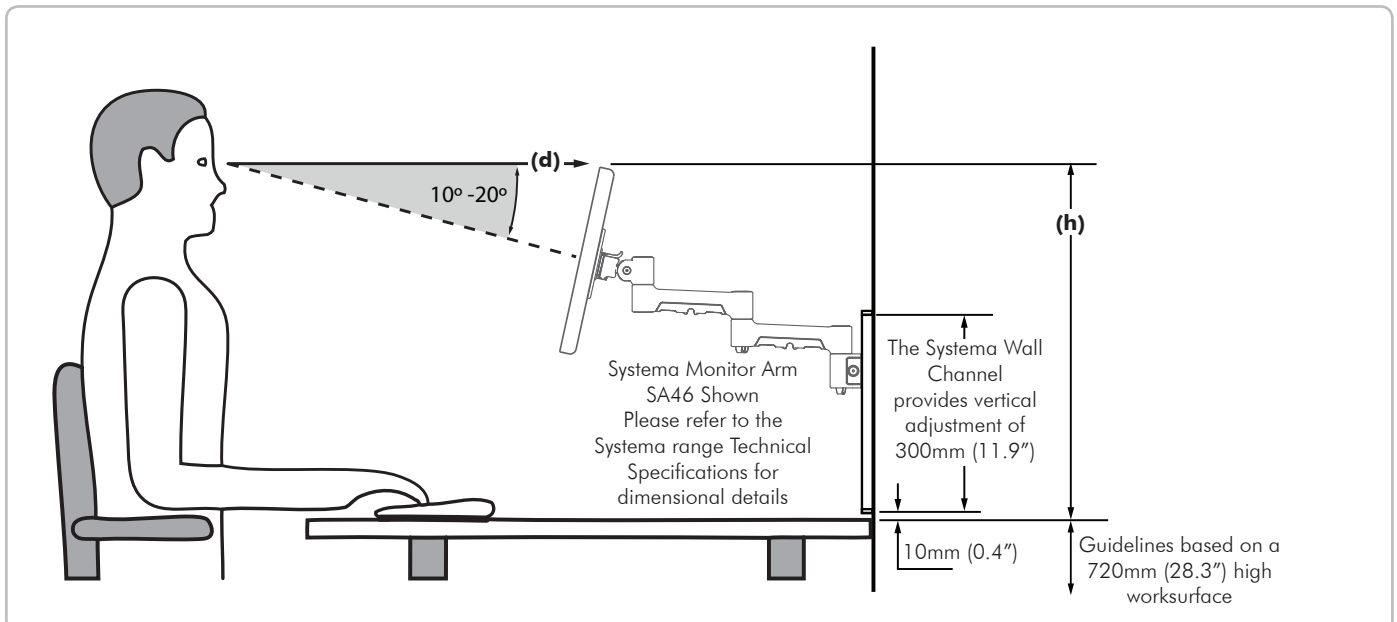

Height: As a guide, the height (**h**) of your display should approximately be as follows:

- Tall Male (Max): 560mm (22")
- Short Male (Min): 368mm (14.5")
- Tall Female (Max): 520mm (20.5")
- Short Female (Min) 356mm (14")

Atdec recommends that the bottom of the wall channel is positioned 10mm above the worksurface to facilitate use by the largest range of people.

Distance: For visual comfort, a viewing distance (**d**) between 500mm (20") to 750mm (29.5") is recommended.

Viewing angle: Ergonomists recommend that the optimal position of your display should be slightly below eye level. When looking at the display's centre the user should have a downward visual angle of approximately 10°-20°.

Step 3. Install Wall Channel

Masonry

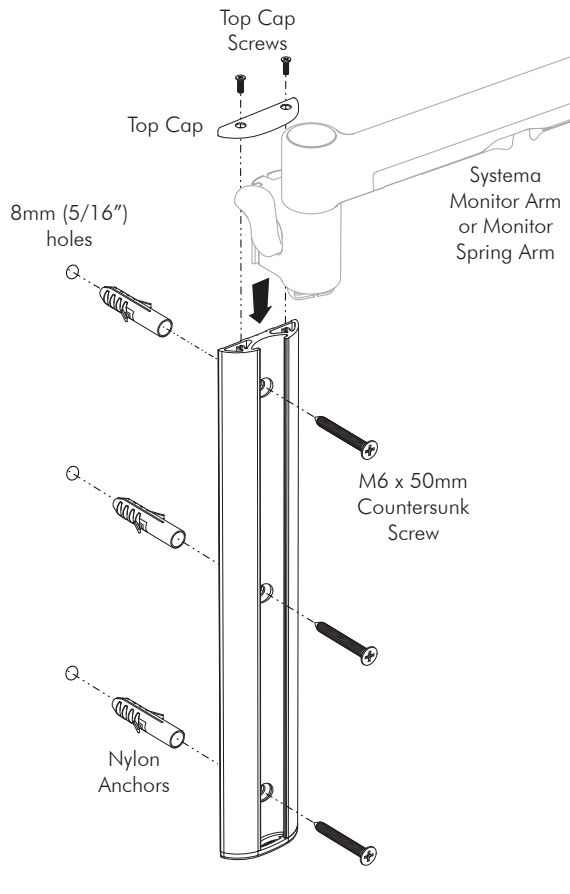

Timber Stud

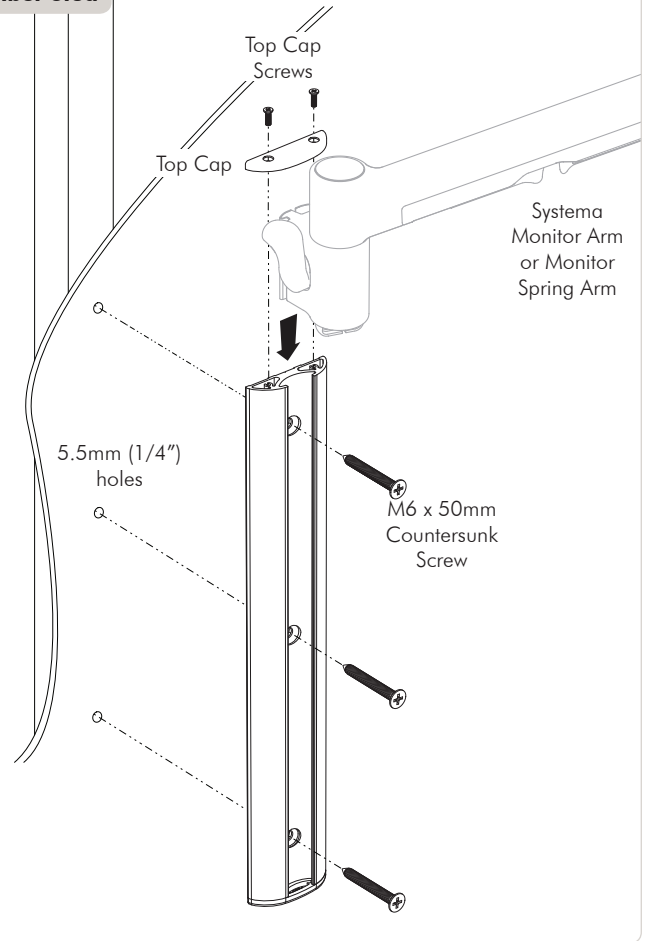

Installation Complete

You are now ready to install your Systema Monitor Arms.
Please refer to the Installation Instructions Included with these products.

